

Seneca Plus

INSTALLATION & MAINTENANCE

PRIOR TO INSTALLATION

MATERIAL REQUIREMENTS:

- Estimate square footage and add 10%.
- Select underlayment (over concrete or in moisture prone areas, the underlayment selected must act as a vapor barrier). If the product you have selected already has a pre-attached underlayment, then a 6 mil vapor barrier must be used over concrete or in moisture prone areas.

ACCLIMATION:

Store in the room for 48 hours. The product should be stored in draught-free, dry rooms. For transportation it is necessary that the packs are protected from the weather.

Storage before installation:

The panels should be stored unopened in the middle of the room. Please store the unopened laminated flooring packs at a room temperature of at least 64.4°F and a relative humidity of $\leq 60\%$ for minimum of 48 hours.

INSTALLATION TOOLS

1. Wood Glue
2. Spacers
3. Pull-bar
4. Circular Saw with a fine-toothed blade
5. Hammer (min. 1 lb)
6. Pencil
7. Straight Edge

GENERAL GUIDELINES

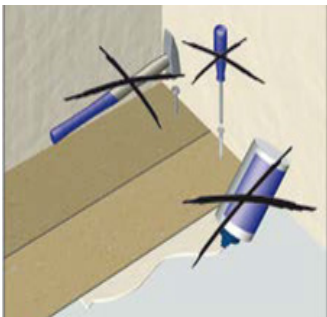

NOTE: Never Use a tapping block or installation kid designed for other laminate floors. Using these tools will damage your floor and void your warranty. This Laminate flooring is designed to be installed floating. Under no circumstances should flooring panels be glued, nailed, screwed or otherwise adhered (e.g. door stopper, closet track) to the subfloor in any way.

- The largest possible continuous installation area is 40' in the direction of the panel width and 40' in the direction of the panel length.

Seneca Plus

INSTALLATION & MAINTENANCE

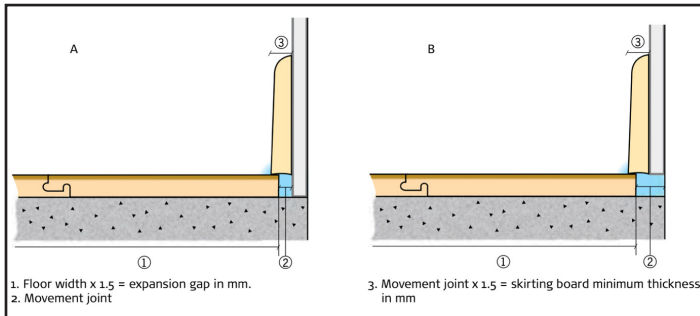

40' is the max length or width before needing transition.

- **General expansion/contraction performance to base recommendations on:**

The dimensions of the base board should never determine the size of the expansion joint. With larger floor areas, the base board should be selected

based on the required size of the expansion space needed, not vice versa. In new construction, a simple way of permitting additional expansion space with thinner base boards is to stop the drywall immediately above the floor surface. If the drywall is for example 1/2", this will allow for an additional 1/2" of expansion space, allowing a thinner base board than would otherwise be necessary. (See above left image.)

A good rule of thumb is that you need 1.1mm for every meter for water resistant laminate flooring.

Example: A 5m long room should have an expansion gap around the perimeter of $5 \times 1.5 \text{ mm} = 8 \text{ mm}$ between the floor and all fixed objects.

For practical reasons, allowing a 10 mm minimum expansion joint for floors less than 6 meters long/wide is recommended.

As the room Length or Width grows longer/wider, it is prudent to add expansion space to allow for the entire length of the adjoining planks to grow unimpeded.

This flooring must be installed as a floating floor and will require using T-moldings in any doorways that are less than 32-inches wide or in the case of changes in plank direction between rooms, regardless of the doorway width.

Please note: the ability of the floor to float must not be constrained by any hardware such as nails, screws, or other fixed obstructions, including glue.

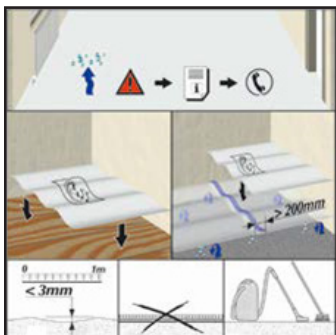

- Installation should be carried out at a room temperature of at least 65°F and a floor temperature of at least 59°F. The relative humidity in the room should be 50-60 %. The temperature difference between the flooring panels and the subfloor should not exceed ± 3 degrees.

- The sub-floor must be absolutely level, dry, clean, and firm. Carpet is not a suitable underlayment. Differences in floor level of more than 3 mm per

Seneca Plus

INSTALLATION & MAINTENANCE

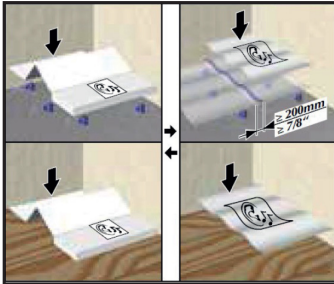

meter span (1/8" on 3") must either be sanded down or filled in with suitable floor filling compound. The subfloor has to be absolutely clean before installing the laminate and free of any debris.

- **Installation on concrete/mineral subfloors**

As the duration of drying depends on climatic conditions, the stated drying periods are to be considered as guidelines. In any case, for safety purposes, two weeks should be added. Absolute certainty can only be guaranteed by

adequate measuring e.g.

- Calcium chloride < 3 lb.
- Relative humidity of 85% or less

- **Installation on wood subfloors**

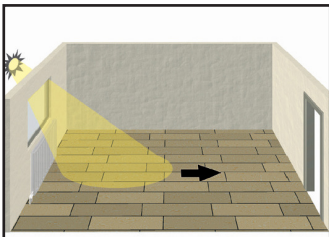

Wooden constructions must be sufficiently ventilated (4cm²/sup_ ventilation area per each m²/sup_ of flooring). Principally sub-floors consisting of wood (chipboard, hardboard and floorboard etc.) must not be covered with airtight materials as beneath the covering the microorganisms find ideal conditions to exist thereby ruining the floor.

Since sufficient ventilation must be allowed, in sections of the installation near the wall wooden strip must be adjusted to allow for ventilation to pass through floor construction, including after the floor is installed. It must be presumed that the existing hollow/space underneath the construction will be constantly dry, to guarantee the balance of moisture of the wooden construction independent of the seasons, and thereby PE film as vapor absorption will not be needed.

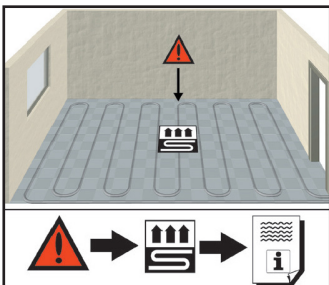

- **PE Film**

A PE film (polyethylene film) or similar of at least 0.2 mm thickness must be laid as a vapor barrier against rising moisture. Allow the PE film to overlap by 1". Use a water resistant tape to tape the overlap joints together. Pull the film 1 1/2 - 2" up the wall.

- **Laying Direction**

Recommended installation direction is lengthwise to the main light source.

Flooring consists of several individual boards. The single planks can always be seen in strong light. The joints are more visible crosswise than lengthwise to the light source. Because of the panel format there are less joints in the length than in the width. This is only recommended because there are also other influences.

- **Installation in Conjunction with Underfloor Heating**

This laminate flooring can be installed trouble-free in conjunction with hot

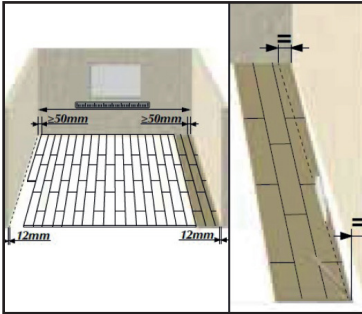

water underfloor heating systems.

- **Panel Mixing**

Prepare at least 4 packs of flooring. Mix panels from different packs during installation. We recommend alternate fitting of the panels from four different packs at the same time. Keep alternating the panels across the entire floor area. This guarantees the best possible appearance of your flooring product.

- **Check for defective panels**

Always carefully inspect the panels for damage before installation. Color, decor, clean edge processing and small damages or visual imperfections on the surface. Panels with minor damage can be used in situations where the panels have to be cut.

The installation has to be done using daylight or equivalent good lighting because it can be possible that small damages can't be recognized. No complaints can be accepted in the case of panels which have already been used.

- **First panel row parallel towards the wall**

Please ensure a minimum of > 2" width of the first and last row. The panels must follow the course of the wall; unevenness 1/5" must be marked on the first row of panels using a spacer. The panels have to be sawn lengthways following the marking. The last row of panels at the opposite wall should not be less than 2" wide, if so, the width of the first row of panels should be cut down lengthways to avoid this. Please make sure that there is a min. distance to the wall of 1/2". Bear this in mind when calculating the last row.

INSTALLATION ILLUSTRATIONS

 **STEP 1:** Remove the tongue of the first panel row and lay it against the wall. Insert the panel at an angle of approx. 25° degrees and lower the panel to lock into place. Connect the panels of the first row on the short side. Insert the panel into the groove of the first panel at an angle of 25° degrees; and lower the panel to lock it into place. Ensure that the row is straight.

STEP 2: Mark length, of last panel in each row to allow for minimum offset to the following rows. For accurate cutting of the last panel in the row, rotate this through 180° degrees; and with the pattern side upwards, place beside the already installed row. Allow for distance from wall at end of panel. Mark out offset and saw off. Always saw from the upper surface of the panel (to avoid splintering the edges) only when using an electric jig saw or a hand-held circular saw should the patterned side be placed facing downwards. Start each row with the left of the left-over piece from the preceding row. The transverse shocks must be set in an appropriate offset. Because of the offset there is stability in the lay up.

Seneca Plus

INSTALLATION & MAINTENANCE

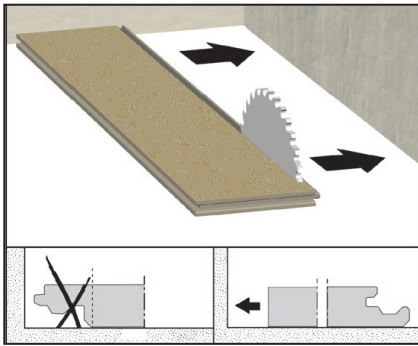

Step 1 Installation Illustration

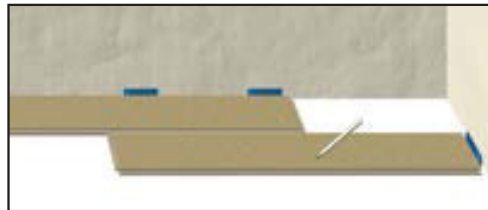

Step 1 Installation Illustration

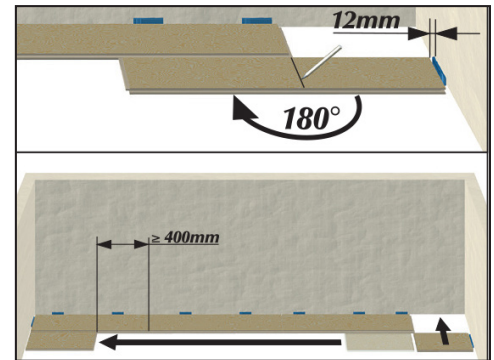

Step 2 Installation Illustration

- **(Longitudinal connection) Angle / Tap**

Place the panel lengthwise at an angle of approx. 25° and angle it in. Shift the panel ahead now to the short side of the first panel. Push the panel down gently so that the prestressed profile locks in neatly. Pay attention to the positioning of the short sides to ensure the profile pieces are perfectly aligned. Once the plank is lying flat, place the tapping block on the profile and use a hammer to gently tap so that the tongue and groove have a tight connection. Please note that the tapping block should be positioned properly on the tongue so damage does not occur.

- **(Diagonal connection) Angle / Tap**

To start the second row, place the plank lengthwise and angle at approx. 25° before dropping the plank down. Install the next plank by angling the long side at approx. 25° and dropping down, keeping in mind the short side should be 2-3mm away from the end of the previous plank. Pay attention to the positioning of the short sides to ensure the profile pieces are perfectly aligned. Once the plank is lying flat, place the tapping block on the profile and use a hammer to gently tap so that the tongue and groove have a tight connection. Please note that the tapping block should be positioned properly on the tongue so damage does not occur.

STEP 3: The panels are laid according to the numbering in the image. (Trim the first row if necessary, as described in Figure for step 3) In this sequence, the first 3 rows are laid out in the room. This way of laying ensures that the rows are connected in straight lines. The pre-installed rows are then pushed against the wall. The distance between the wall and the panel rows is fixed with space wedges. After that, the laying can be continued row by row.

STEP 4: Special cases: If you are not able to angle the panels (e.g. under a door frame or low fitted radiator) cut away the locking edge, Glue and tap the panels tight together. If you are not able to angle the panels (e.g. under a door frame or low fitted radiator) you have to cut away the locking edge of lip of the bottom groove by using a wood chisel or a small block plane. Run a bead of glue on the

Seneca Plus

INSTALLATION & MAINTENANCE

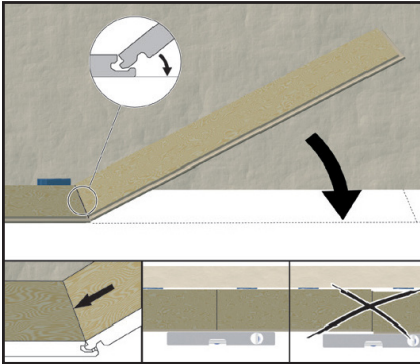

Step 2 Installation Illustration

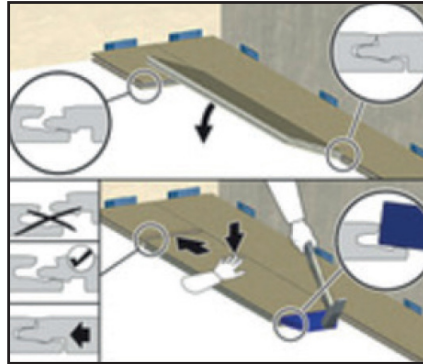

Step 2 Installation Illustration

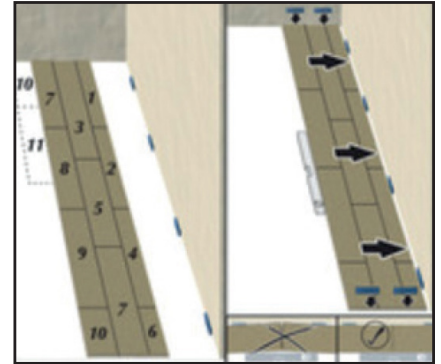

Step 3 Installation Illustration

modified tongue and groove. Tap the panels tight together by using a hammer and push block or pull-bar. If necessary fix it with an adhesive tape.

STEP 5: Position the panel row so that a transverse joint coincides with the pipe. Join up the sawn off piece again tightly behind the heating pipe (using the spacer). Position the panel row so that a transverse joint coincides with the pipe. First cut the panel to the correct length. Then lay the panel section beside the actual position, measure the recesses with the ruler and draw in.

STEP 6:

- **Installation towards wooden door frames**

Minimum distance 1/2". Lay a panel next to the door frame (with the patterned side facing downwards) Cut into the door frame with the straight back saw. Then slide the panel under the frame with the patterned side upwards Don't forget to allow for freedom of movement here to 1/2".

- **Installation towards metal door frames**

Minimum distance 1/2". Mark the measurements of the metal door frame on the panel, remember the necessary distance 1/2" on each side. Now saw out the marked section. Place the panel and make sure, that the freedom of movement is given 1/2".

STEP 7: Lay a panel exactly on the previous row. Lay a second panel (original width) on the top of it and draw an exact line for cutting. Cut away excess wood. Join the panel lengthways. Minimum expansion gap 1/16" on 3'. Measure the exact width of the last panel row. To do this lay a panel on the previous panel row. Then lay a second panel on the panel to be measured with the tongue to the wall and use as a straight edge. Cut away excess wood. Minimum expansion gap 1/16" on 3'. Insert the panel lengthways and lower down.

STEP 8: Continue the installation in this manner until you get to the last row. For the last row, measure the exact width required. To do this, lay a plank of flooring on the second to last row. Then lay a

Seneca Plus

INSTALLATION & MAINTENANCE

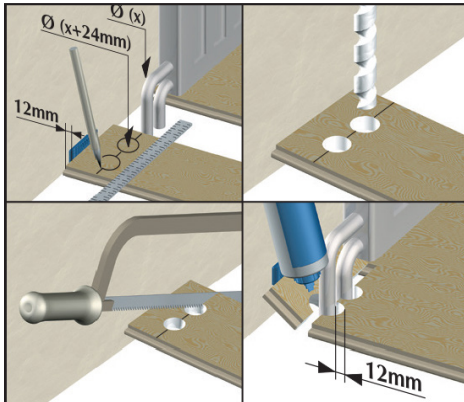

Step 5 Installation Illustration

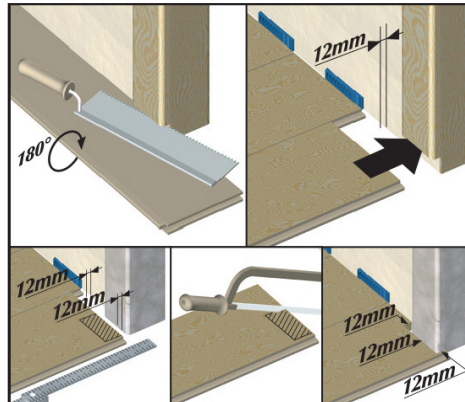

Step 6 Installation Illustration

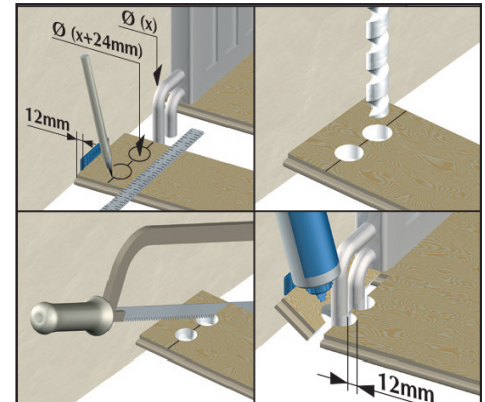

Step 7 Installation Illustration

second plank of flooring on top of this plank with the tongue side of the plank touching the wall. This will allow you to determine the width needed for the final row. Make a mark with a pencil and cut with a saw along this mark. Expansion gap must be respected!

HOW TO REPLACE LAMINATE PLANKS

1. To repair damaged laminate planks, start with drilling a ½" hole on each corner of the damaged laminate plank. You will want to be as close as possible to the plank end joints. Drill two or three more holes on each side of the damaged laminate plank approximately 4" to 5" from each other.
2. Draw a straight line between the holes to prevent mistakes and use it as a cutting guide.
3. Make sure you stick to the exact depth of the laminate when using the saw so you prevent cutting into the underlayment or sub-floor which you definitely do not want.
4. Begin in the center of the laminate plank, cut along the lines to the inner holes and continue to the holes that you drilled.
5. Cut out the center piece or lift it out. If necessary, you can use a utility knife to lift it up.
6. Remove the remaining pieces of the board by rocking them up and down. Be gentle and very careful during this step because you could cause damage to the laminate floor planks next to the damaged one. You definitely want to pay attention to the adjoining laminate floor planks.
7. Make sure the area is cleaned up from any excess. You want it to be nice and clean before you install the new plank.
8. Now it comes time for the replacement laminate plank. You have to cut off the tongue on both sides, the short and long edge of the board. Laminate flooring brands may also require trimming of the groove along a short edge so the new plank will sit in place. The best tool to do it will be a vibratory undercut saw.
9. Now that the damaged laminate plank is out of the way, it is time to install the new laminate plank. Apply a few drops of glue to the groove of the uncut plank (the one that was connected to the damaged plank). You should apply glue to all seams and joints but only a few drops. Wipe off any extra glue that

you may have before it dries. If you use too much glue, the ends may swell later. Remember, only a few drops. Perhaps only three on the short ends and one drop every six inches on the long.

10. You should place something heavy on the plank and let it dry for the day.

CARE AND MAINTENANCE

Installation in an area that is susceptible to spills or liquid

If the installation is to take place in an area that is susceptible to spills or liquid getting behind molding boards, the perimeter of the room must be completely sealed. A 3/8" compressible polyethylene (PE) foam backer rod should be inserted to fill all expansion spaces. The backer rod should be completely covered with 100% silicone sealant around the entire perimeter of the installation.

An acrylic sealant should not be used. A small silicone bead should be applied where the molding meets the floor, creating a perimeter barrier to prevent any spills or liquids from getting underneath or behind the skirting. The same result can be achieved with waterproof skirting. Any fixed objects, door frames, etc. should be sealed in the same way using a 100% silicone sealant.

Vacuum, dust mop (dry) and when necessary, clean with a MOIST (not wet) cloth or mop. NEVER USE wet cleaning tools and cleaners, soaps, floor polish, floor cleaning wax, oil soaps, etc. These products can damage and/or leave a film on the flooring.

The use of a steam cleaner is allowed if the steam is not being applied directly to the laminate floor. Use the steam cleaner with a clean soft cloth or rag between the steam opening and the flooring, this will also guarantee a homogeneous heat and steam distribution. It is also important that you not hold the steam apparatus on the same spot for any length of time and clean the floor in the lengthwise direction of the design. The use of a wet jet mop is allowed, provided it sprays a small amount of water in front of the cloth to clean the floor. In all cases, liquid buildup on the floor should be avoided.

TIPS:

- Use felt tip protectors
- Area rug use is recommended
- Keep animal nails trimmed
- Never slide furniture across floor without pads
- Keep floors clean
- Never use water or wet type cleaning tools

PLEASE NOTE: It is normal to have occasional sounds walking over any floating floor since it is not nailed or glued. This does not diminish the warranty of the product and should be anticipated. Sounds may vary or go away during heating and cooling seasons throughout the year that relate to the home's relative humidity fluctuations.